

TM9500 • TM9502 • TM13500 • TM13502 • TM17500



TM Series Submersible Low Head Waterfall Pumps

Instructions for Operation • Safety • Warranty

Thank you for purchasing the TM series waterfall pump. This instruction manual explains the product operations and gives important precautions regarding its safe use. In order to use the product to maximum benefit, be sure to read the instructions thoroughly and follow them carefully.

To avoid accident, do not use the pump in any way other than as described in this instruction manual especially when you see "WARNING". After reading this instruction manual, keep it nearby as a reference in case questions arise during use.

If this instruction manual should become lost or damaged, ask your nearest dealer or representative for another copy.

Safety & Electrical Connections



WARNING: Verify that the voltage and frequency of the electric pump shown on the nameplate correspond to those available on the mains.

The installer must make sure that the electric system is grounded in accordance with local ordinances.

The plug and connections should be protected from water/rain. Before using the pump, always inspect it visually (especially power cable and plug).

Do not use the pump if it is damaged.

If the pump is damaged, have it inspected by a qualified service center only.

Make sure that electric connections are protected from all water and moisture. Protect the plug and the power cable from heat, oil or sharp edges.



WARNING: The power cable must be replaced by qualified personnel only.

Grounding: The plug of the power cable has a double grounding contact, so that grounding can be performed by simply inserting the plug.

Overload Protection: EasyPro pumps have a built in thermal protection switch. The pump stops if an overload condition occurs. The motor restarts automatically after it has cooled down.

Prior to Operation

Check the following points upon receipt of your pump:

Is the pump exactly what you ordered? Check nameplate. Has any damage occurred during shipment? Are any bolts or nuts loose? Have all necessary accessories been supplied? We recommend that you keep a spare pump on hand in case of emergencies. Keep this instruction manual in a place for future reference.



Specifications

Model	HP	Volts	Max. Amps	Weight	Dimensions	Max. Head	Max. Flow
TM9500/TM9502	1	115/230	10.9/5.5	52 lbs.	12" x 7.5" x 19.5"	31'	9500 GPH
TM13500/TM13502	1.5	115/230	12/6	58 lbs.	12" x 7.5" x 20"	33'	13500 GPH
TM17500	2	230	10	70 lbs.	12.6" x 8.6" x 22.5"	40'	17500 GPH

Pump Performance Chart

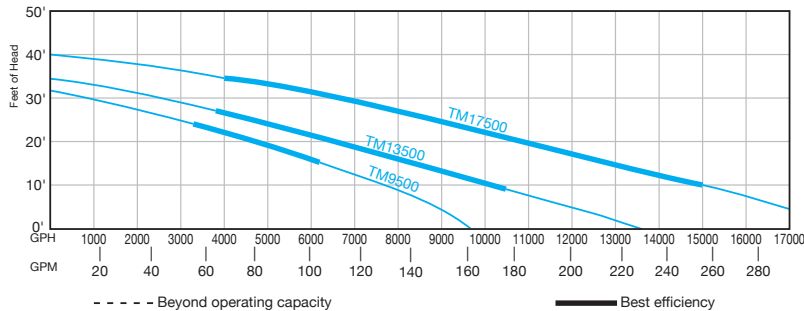

Installation

Symbol and Meaning



DANGER

Keep the pump equipment out of the reach of children!

Warns that failure to follow directions could cause serious risk/injury to individuals or objects.



WARNING

This sign warns the operator that the failure to follow an instruction may damage the pump and/or the system.

Limitations

This pump must stay submerged entirely when operating. If used in skimmer, the debris net must be kept clean to ensure adequate water flow to the pump. Running pump low on water will cause overheating and premature failure which is not covered under warranty.

This series of pumps are suitable to pump rain water and also can be used both for permanent and temporary installation. The pump can be placed in a sump pit, then can pump dirty water containing suspended solid particles up to 1/2" diameter.



WARNING: The pump cannot be used for sea water, chlorinated water and flammable, corrosive, explosive or dangerous liquids.

Installation

WARNING:

Do not work on pump until power is unplugged.

Do not cut off ground pin or use an adapter fitting.

Do not use an extension cord

Must be used on a GFCI protected outlet

Do install the strainer prior to using if you want to let the pump run as a sump pump.



The pump power cord should be connected to a separately fused, grounded line with a minimum capacity of 15 amps. It can be connected to non-fuse breaker at the recommended amps. Never touch the pump when it is plugged in.

1. Before installing or servicing this pump, be certain pump power source is disconnected. Contact a qualified licensed electrician for disconnecting electrical service prior to pump removal.
2. Installation and electrical wiring must adhere to state and local codes and must be completed before priming pump. Check appropriate community agencies, or contact local electrical and pump professionals.
3. Call an electrician when in doubt. Pump should be connected to a separate 15 amp circuit breaker or 15 amp fuse block. Note that, plugging into existing outlets may cause low voltage at motor, causing blown fuses, tripping of motor overload or burned out motor.
4. A permanent ground connection from pump to the grounding bar at the service panel is mandatory. For maximum safety, connect pump to a circuit equipped with a Ground Fault Circuit Interrupter device when you position the pump's grounding wire.
5. Voltage of power supply must match the voltage of the pump.



WARNING: Must be vented in accordance with local plumbing codes. EasyPro pumps are not designed for and CANNOT be installed in locations classified as hazardous.



WARNING: The following may cause severe damage to pump and will void warranty:

- Using an extension cord
- Cutting off the ground pin or using an adapter fitting
- Working on pump or switch while plugged in
- Removing motor housing, unscrewing impeller or otherwise removing impeller seal
- Pumping chemicals or corrosive liquids, including chlorinated or salt water
- Pumping gasoline or other flammable liquids
- Piping: Plastic PVC pipe, drain hose, galvanized steel or copper pipe may all be used. All piping must be clean and free of all foreign matter to prevent clogging. Use thread compound on all threaded joints unless specified otherwise. Be sure to seal the thread connection with tape seal when you are using the pipe fitting to connect the flange.

Replacement Parts

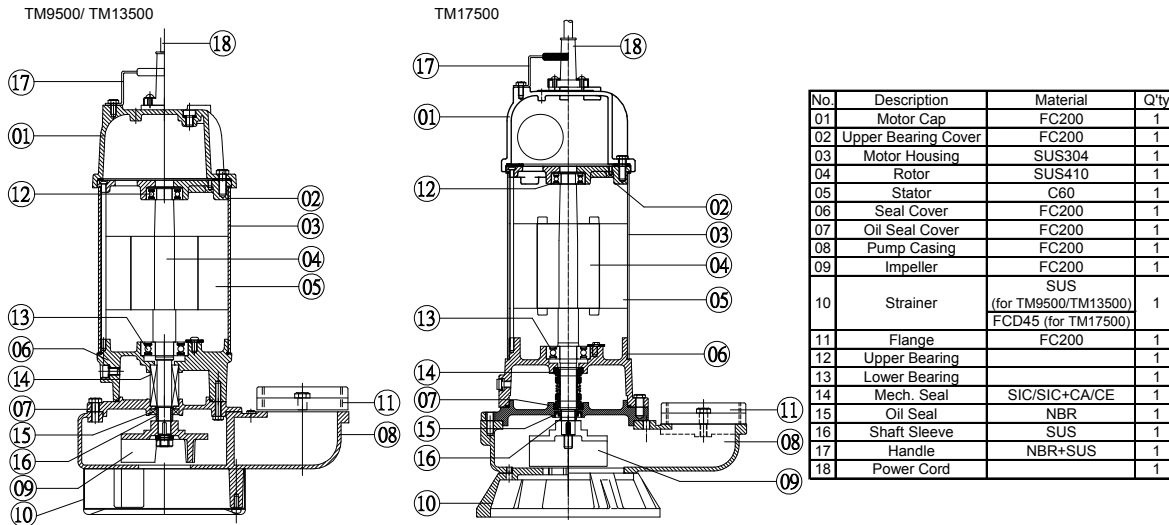

Troubleshooting

Problem	Possible Causes
Pump hums	<ul style="list-style-type: none"> • Line circuit breaker is off, or fuse is burned or loose. • Water level in sump has not reached turn-on level as indicated in installation drawing on the carton. • Pump cord is not making contact in receptacle. • Float (optional) is stuck. It should operate freely in basin. • If all of the above are OK and then the motor should operate.
Pump runs but does not deliver water	<ul style="list-style-type: none"> • Check valve (optional) is installed backwards (not included with pump), arrow on valve should point in direction of flow. • Discharge shut-off valve (if used) may be closed. • Impeller or volute openings are fully or partially clogged, remove pump and clean. • Pump is air-locked, start and stop several times by plugging and unplugging cord, check for clogged vent hole in pump case. • Inlet holes in pump base are clogged, remove pump and clean the openings. • Vertical pumping distance is too high or the pipe size is too small, reduce vertical distance or increase the pipe size fittings.
Pump runs but delivers only a small amount of water	<ul style="list-style-type: none"> • Pump is air-locked, start and stop several times by plugging and unplugging cord, check for clogged vent hole in pump case. • Vertical pumping distance is too high or pipe size is too small, reduce vertical distance or increase the pipe size. • Inlet holes in pump base are clogged, remove pump and clean the openings. • Impeller or volute openings are fully or partially clogged, remove pump and clean. • Pump impeller is partially clogged with debris, causing motor to run slow and overload, remove pump and clean.
Fuse blows or circuit breaker trips when pump starts	<ul style="list-style-type: none"> • Pump impeller is partially clogged with debris causing motor to run slow and overload, remove pump and clean. • Motor stator may be defective. • Fuse size or circuit breaker may be too small (must be 15 amps). • Impeller or volute opening are fully or partially clogged, remove pump and clean.
Motor runs for a short time, then stops	<ul style="list-style-type: none"> • Inlet holes in pump base are clogged, remove pump and clean the openings. • Pump impeller is partially clogged with debris causing motor to run slow and overload, remove pump and clean. • Motor stator may be defective.

Each year we receive numerous pumps back that simply have a small stone lodged in the impeller, are plugged from lack of cleaning or do not work due to low voltage caused by an overloaded circuit. These are not warranty items. Please take the time to verify your problem is actually a defective pump before returning. EasyPro will pay postage to return pump to you provided it is a warranty issue. If you send a pump in for warranty and it checks out fine — you will also be responsible for the cost of return postage.

EasyPro Pond Products Limited Warranty

EasyPro Pond Products ("EasyPro") warrants to the purchaser that this product ("Product") will be free from any mechanical or material defects for a period of **two years** from the date of purchase. This warranty only covers properly installed and maintained Products sold by authorized EasyPro Sellers who are subject to and follow EasyPro's quality control standards. Please note that because EasyPro is unable to control the quality of Products sold by unauthorized sellers, unless otherwise prohibited by law, this warranty does not cover Products purchased from unauthorized sellers.

This warranty does not cover normal wear and tear, nor any deterioration suffered through overloading, improper use, negligence, improper installation, acts of God or accident. Similarly, any modification made by the purchaser to the Product will cause the warranty to be null and void. This warranty does not cover any cost associated with the installation or removal of the Product subject to a warranty claim.

All returned items will be inspected to determine cause of failure before a warranty claim is approved. The exclusive remedies provided hereunder shall, upon EasyPro's inspection and option, be either repair or replacement of the Product or parts covered under this warranty.

Making a Claim: A Return Authorization ("RA") number must first be obtained by calling EasyPro at 800-448-3873 or via email at warranty@easypro.com. It is the purchaser's responsibility to pay the return shipping charges. Be sure to include the RA number, original receipt (in the form of an invoice or sales receipt), your name, your return address and your phone number inside of the package. No warranty claims will be honored without the original receipt that shows that your purchase was made from an Authorized EasyPro Seller. Ensure the product is properly packaged and insured for the replacement value. Damage due to improper packaging is the responsibility of the sender.

ALL OTHER EXPRESS OR IMPLIED WARRANTIES INCLUDING MERCHANTABILITY OF FITNESS FOR A PARTICULAR PURPOSE ARE HEAREBY LIMITED IN DURATION TO THE DURATION OF THE WARRANTY AS DESCRIBED ABOVE. Some States do not allow limitations on how long an implied warranty lasts, so the above limitations may not apply to you.

EasyPro shall not be held liable for any damages caused by defective components or materials of this Product; or for loss incurred because of the interruption of service; or any consequential/incidental damages and expenses arising from the production, sale, use or misuse of this Product. Some States do not allow the exclusion or limitation of incidental or consequential damages, so the above limitation or exclusion may not apply to you.

EasyPro shall not be held liable for any loss of fish, plants or any other livestock as a result of any failure or defect of this Product. This warranty gives you specific legal rights, and you may also have other rights that vary from State to State.

